

Power-Stud™ *Wedge Expansion Anchor*
Mechanically Galvanized and Stainless Steel Versions

PRODUCT DESCRIPTION

The Power-Stud anchor, is a fully threaded, torque-controlled, wedge expansion anchor. It is available in a threaded version suitable for applications in solid concrete and grout-filled concrete masonry. The threaded version is produced in mechanically galvanized carbon steel and stainless steel to offer various levels of corrosion resistance depending on use.

GENERAL APPLICATIONS AND USES

- Lighting Standards and Base Plates
- Sills and Support Ledgers
- Retrofit Projects and Machinery Anchorage
- Food and Beverage Facilities
- Water Treatment Plants and Marine Applications

FEATURES AND BENEFITS

- + Fully threaded, medium duty all-purpose anchor
- + Length ID stamped on each threaded anchor
- + Anchors can be installed through the fixture for hole spotting not required
- + Chamfered impact section prevents damage to threads
- + Clip design prevents spinning during installation
- + Nominal drill bit diameter same as anchor diameter

APPROVALS AND LISTINGS

Tested in accordance with ASTM E488 and AC01 criteria
 FM Global (Factory Mutual) – File No. J.I. OK3A9.AH (see ordering information)
 Underwriters Laboratory (UL Listed) – File No. EX1289 (see ordering information)
 Federal GSA Specification
 Meets the descriptive and proof load requirements of CID A-A-1923A, Type 4

GUIDE SPECIFICATIONS

CSI Divisions: *03151-Concrete Anchoring, 04081-Masonry Anchorage and 05090-Metal Fastenings.* Expansion Anchors shall be Power-Stud as supplied by Powers Fasteners, Inc., Brewster, NY.

SECTION CONTENTS	Page No.
General Information	1
Installation Specifications	2
Material Specifications	4
Performance Data	5
Design Criteria	10
Ordering Information	14

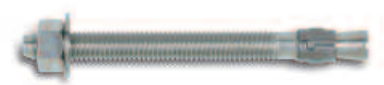

Threaded Power-Stud Assembly

HEAD STYLES

Threaded Stud

ANCHOR MATERIALS

Mechanically Galvanized Carbon Steel
 Type 304 Stainless Steel
 Type 316 Stainless Steel

ANCHOR SIZE RANGE (TYP.)

1/4" diameter through 1" diameter

SUITABLE BASE MATERIALS

Normal-weight Concrete
 Structural Lightweight Concrete
 Grouted Concrete Masonry (CMU)

INSTALLATION SPECIFICATIONS

Mechanically Galvanized Carbon Steel Power-Stud

Dimension	Anchor Diameter, <i>d</i>				
	1/2"	5/8"	3/4"	7/8"	1"
ANSI Drill Bit Size, d_{bit} (in.)	1/2	5/8	3/4	7/8	1
Fixture Clearance Hole, d_h (in.)	9/16	11/16	13/16	15/16	1-1/8
Thread Size (UNC)	1/2-13	5/8-11	3/4-10	7/8-9	1-8
Nut Height (in.)	7/16	35/64	41/64	3/4	55/64
Washer O.D., d_w (in.)	1 1/16	1 3/4	2	2 1/4	2 1/2
Wrench Size (in.)	3/4	15/16	1 1/8	1 5/16	1 1/2
Tightening Torque, T_{inst} (ft-lbs)	60	90	175	250	300

Tightening torque is listed for anchors installed in normal-weight concrete. Consult performance data tables for other base materials.

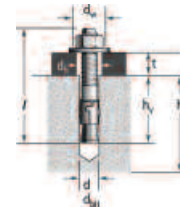

Nomenclature

- d = Diameter of anchor
- d_{bit} = Diameter of drill bit
- d_h = Diameter of fixture clearance hole
- d_w = Diameter of washer
- h = Base material thickness.
The minimum value of h should be $1.5h_v$ or 3" whichever is greater
- h_v = Minimum embedment depth
- l = Overall length of anchor
- t = Fixture thickness

Type 304 and Type 316 Stainless Steel Power-Stud

Dimension	Anchor Diameter, <i>d</i>						
	1/4"	3/8"	1/2"	5/8"	3/4"	7/8"	1"
ANSI Drill Bit Size, d_{bit} (in.)	1/4	3/8	1/2	5/8	3/4	7/8	1
Fixture Clearance Hole, d_h (in.)	5/16	7/16	9/16	11/16	13/16	15/16	1-1/8
Thread Size (UNC)	1/4-20	3/8-16	1/2-13	5/8-11	3/4-10	7/8-9	1-8
Nut Height (in.)	7/32	21/64	7/16	35/64	41/64	3/4	55/64
Washer O.D (304 SS), d_w (in.)	5/8	13/16	1 1/16	1 3/4	2	2 1/4	2 1/2
Washer O.D (316 SS), d_w (in.)	5/8	7/8	1 1/4	1 1/2	1 3/4	2	2
Wrench Size (in.)	7/16	9/16	3/4	15/16	1 1/8	1 5/16	1 1/2
Tightening Torque, T_{inst} (ft-lbs)	8	28	60	90	175	250	300

Tightening torque is listed for anchors installed in normal-weight concrete. Consult performance data tables for other base materials.

INSTALLATION PROCEDURES

Threaded Stud Version



Using the proper diameter bit, drill a hole into the base material to a depth of at least 1/2" or one anchor diameter deeper than the embedment required. The tolerances of the drill bit used must meet the requirements of ANSI Standard B212.15

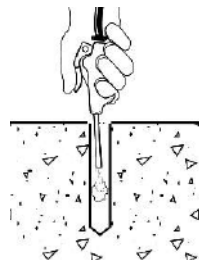

Blow the hole clean of dust and other material. Do not expand the anchor prior to installation



Position the washer on the anchor and thread on the nut. Drive the anchor through the fixture into the anchor hole until the nut and washer are firmly seated against the fixture. Be sure the anchor is driven to the required embedment depth

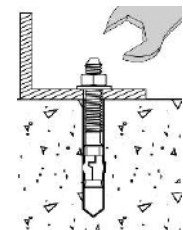

Tighten the anchor by turning the nut 3 to 5 turns past finger tight or by applying the guide installation torque from the finger tight position.

MATERIAL SPECIFICATIONS

Anchor Component	Mechanically Galvanized Carbon Steel Power-Stud
Anchor Body	AISI 1018 (1/2" – 3/4", lengths up to 7")
	AISI 12L14 (7/8" – 1" and all lengths over 7")
Nut	Carbon Steel, ASTM A563, Grade A
Washer	AISI 1010 Carbon Steel, Meets Dimensional Requirements of ANSI/ASME 18.22.1, Type A Plain
Expansion Wedge	Type 304 Stainless Steel
Zinc Plating	ASTM B695, Class 65, Type I

Anchor Component	Type 304 Stainless Steel Power-Stud	Type 316 Stainless Steel Power-Stud
Anchor Body	Type 304Cu (1/4" – 3/4", lengths up to 7")	Type 316 Stainless Steel
	Type 304 (7/8" – 1", lengths over to 7")	
Nut	Type 18-8 (300 Series) Stainless Steel	Type 316 Stainless Steel
Washer	Type 18-8 (300 Series) Stainless Steel	Type 316 Stainless Steel
Expansion Wedge	Type 304 Stainless Steel	Type 316 Stainless Steel

Stainless steel anchor components are passivated.

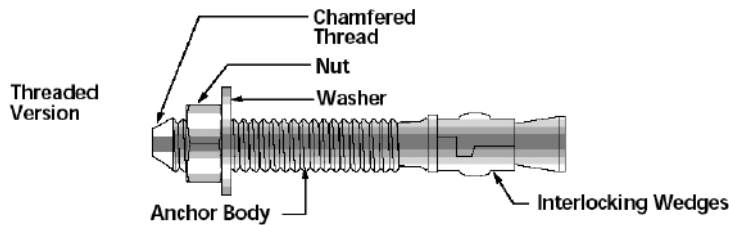

Length Identification (threaded version)

Mark	◆	■	A	B	C	D	E	F	G	H	I
From	1/2"	1"	1-1/2"	2"	2-1/2"	3"	3-1/2"	4"	4-1/2"	5"	5-1/2"
Up to but not including	1"	1-1/2"	2"	2-1/2"	3"	3-1/2"	4"	4-1/2"	5"	5-1/2"	6"

Mark	J	K	L	M	N	O	P	Q	R	S	T
From	6"	6-1/2"	7"	7-1/2"	8"	8-1/2"	9"	9-1/2"	10"	11"	12"
Up to but not including	6-1/2"	7"	7-1/2"	8"	8-1/2"	9"	9-1/2"	10"	11"	12"	13"

PERFORMANCE DATA

Ultimate Load Capacities for Mechanically Galvanized Carbon Steel Power-Stud in Normal-Weight Concrete^{1,2}

Anchor Diameter <i>d</i> in. (mm)	Minimum Embedment Depth <i>h_v</i> in. (mm)	Minimum Concrete Compressive Strength (<i>f'_c</i>)					
		2,000 psi (13.8 MPa)		4,000 psi (27.6 MPa)		6,000 psi (41.4 MPa)	
		Tension lbs. (kN)	Shear lbs. (kN)	Tension lbs. (kN)	Shear lbs. (kN)	Tension lbs. (kN)	Shear lbs. (kN)
1/4 (6.4)	1 1/8 (28.6)	1,240 (5.6)	1,580 (7.1)	1,440 (6.5)	1,620 (7.3)	1,740 (7.8)	1,620 (7.3)
	1 5/8 (41.3)	1,920 (8.6)	3,560 (16.0)	3,040 (13.7)	3,760 (16.9)	3,040 (13.7)	3,760 (16.9)
3/8 (9.5)	2 (50.8)	2,800 (12.6)	3,560 (16.0)	3,850 (17.3)	3,760 (16.9)	4,075 (18.3)	3,760 (16.9)
	2 1/4 (57.2)	3,440 (15.5)	6,540 (29.4)	5,560 (25.0)	6,800 (30.6)	6,540 (29.4)	6,800 (30.6)
	3 (76.2)	5,100 (23.0)	6,540 (29.4)	8,160 (36.7)	6,800 (30.6)	9,200 (41.4)	6,800 (30.6)
1/2 (12.7)	4 (101.6)	5,700 (25.7)	6,540 (29.4)	8,160 (36.7)	6,800 (30.6)	9,200 (41.4)	6,800 (30.6)
	2 3/4 (69.9)	6,240 (27.8)	9,280 (41.8)	8,300 (37.4)	11,900 (53.6)	9,860 (44.4)	11,900 (53.6)
5/8 (15.9)	4 (101.6)	9,600 (43.2)	9,280 (41.8)	10,825 (48.7)	11,900 (53.6)	13,495 (60.7)	11,900 (53.6)
	3 3/8 (85.7)	7,420 (33.0)	12,380 (55.7)	9,500 (42.3)	15,060 (67.8)	11,540 (51.3)	15,060 (67.8)
3/4 (19.1)	5 (127.0)	10,640 (47.3)	12,380 (55.7)	14,630 (65.8)	15,060 (67.8)	14,630 (65.8)	15,060 (67.8)
	3 7/8 (98.4)	7,600 (34.2)	17,960 (80.8)	12,300 (55.4)	24,160 (108.7)	17,300 (77.9)	24,160 (108.7)
7/8 (22.2)	4 1/2 (114.3)	9,600 (43.2)	17,960 (80.8)	15,620 (70.3)	24,160 (108.7)	20,075 (90.3)	24,160 (108.7)
	5 3/4 (146.1)	10,640 (47.3)	17,960 (80.8)	19,880 (89.5)	24,160 (108.7)	25,625 (115.3)	24,160 (108.7)
	4 1/2 (114.3)	8,740 (39.3)	26,420 (118.9)	13,820 (62.2)	31,100 (140.0)	21,220 (94.4)	31,100 (140.0)
1 (25.4)	5 1/2 (139.7)	12,770 (57.5)	26,420 (118.9)	20,280 (91.3)	31,100 (140.0)	27,800 (123.7)	31,100 (140.0)
	6 1/2 (165.1)	16,605 (74.7)	26,420 (118.9)	25,485 (114.7)	31,100 (140.0)	34,360 (152.8)	31,100 (140.0)

1. Tabulated load values are for anchors installed in concrete. Concrete compressive strength must be at the specified minimum at the time of installation.

2. Ultimate load capacities must be reduced by a minimum safety factor of 4.0 or greater to determine allowable working load. Consideration of safety factors of 10 or higher may be necessary depending upon the application such as life safety or overhead.

PERFORMANCE DATA

Allowable Load Capacities for Mechanically Galvanized Carbon Steel Power-Stud in Normal-Weight Concrete^{1,2,3}

Anchor Diameter <i>d</i> in. (mm)	Minimum Embedment Depth <i>h_v</i> in. (mm)	Minimum Concrete Compressive Strength (<i>f'_c</i>)					
		2,000 psi (13.8 MPa)		4,000 psi (27.6 MPa)		6,000 psi (41.4 MPa)	
		Tension lbs. (kN)	Shear lbs. (kN)	Tension lbs. (kN)	Shear lbs. (kN)	Tension lbs. (kN)	Shear lbs. (kN)
1/4 (6.4)	1 1/8 (28.6)	310 (1.4)	395 (1.8)	360 (1.6)	405 (1.8)	435 (2.0)	405 (1.8)
	1 5/8 (41.3)	480 (2.2)	890 (4.0)	760 (3.4)	940 (4.2)	760 (3.4)	940 (4.2)
3/8 (9.5)	2 (50.8)	700 (3.2)	890 (4.0)	965 (4.3)	940 (4.2)	1,020 (4.6)	940 (4.2)
	2 1/4 (57.2)	860 (3.9)	1,635 (7.4)	1,390 (6.3)	1,700 (7.7)	1,635 (7.4)	1,700 (7.7)
1/2 (12.7)	3 (76.2)	1,275 (5.7)	1,635 (7.4)	2,040 (9.2)	1,700 (7.7)	2,300 (10.4)	1,700 (7.7)
	4 (101.6)	1,425 (6.4)	1,635 (7.4)	2,040 (9.2)	1,700 (7.7)	2,300 (10.4)	1,700 (7.7)
	2 3/4 (69.9)	1,560 (6.9)	2,320 (10.4)	2,075 (9.3)	2,975 (13.4)	2,465 (11.1)	2,975 (13.4)
5/8 (15.9)	4 (101.6)	2,400 (10.8)	2,320 (10.4)	2,705 (12.2)	2,975 (13.4)	3,375 (15.2)	2,975 (13.4)
	3 3/8 (85.7)	1,855 (8.3)	3,095 (13.9)	2,375 (10.6)	3,765 (16.9)	2,375 (10.6)	3,765 (16.9)
3/4 (19.1)	5 (127.0)	2,660 (11.8)	3,095 (13.9)	3,660 (16.5)	3,765 (16.9)	3,660 (16.5)	3,765 (16.9)
	3 7/8 (98.4)	1,900 (8.6)	4,490 (20.2)	3,075 (13.8)	6,040 (27.2)	4,325 (19.5)	6,040 (27.2)
7/8 (22.2)	4 1/2 (114.3)	2,400 (10.8)	4,490 (20.2)	3,905 (17.6)	6,040 (27.2)	5,305 (23.6)	6,040 (27.2)
	5 3/4 (146.1)	2,660 (11.8)	4,490 (20.2)	4,970 (22.4)	6,040 (27.2)	6,950 (30.9)	6,040 (27.2)
	4 1/2 (114.3)	2,185 (9.8)	6,605 (29.7)	3,455 (15.5)	7,775 (35.0)	5,305 (23.6)	7,775 (35.0)
1 (25.4)	5 1/2 (139.7)	3,195 (14.4)	6,605 (29.7)	5,070 (22.8)	7,775 (35.0)	6,950 (30.9)	7,775 (35.0)
	6 1/2 (165.1)	4,150 (18.7)	6,605 (29.7)	6,370 (28.7)	7,775 (35.0)	8,590 (38.2)	7,775 (35.0)

1. Allowable load capacities listed are calculated using and applied safety factor of 4.0. Consideration of safety factors of 10 or higher may be necessary depending upon the application such as life safety or overhead.
2. Allowable load capacities are multiplied by reduction factors found in the Design Criteria section when anchor spacing or edge distances are less than critical distances.
3. Linear interpolation may be used to determine allowable loads for intermediate embedments and compressive strengths.

PERFORMANCE DATA

Ultimate Load Capacities for Stainless Steel Power-Stud in Normal-Weight Concrete^{1,2}

Anchor Diameter <i>d</i> in. (mm)	Minimum Embedment Depth <i>h_v</i> in. (mm)	Minimum Concrete Compressive Strength (<i>f'_c</i>)					
		2,000 psi (13.8 MPa)		4,000 psi (27.6 MPa)		6,000 psi (41.4 MPa)	
		Tension lbs. (kN)	Shear lbs. (kN)	Tension lbs. (kN)	Shear lbs. (kN)	Tension lbs. (kN)	Shear lbs. (kN)
1/4 (6.4)	1 1/8 (28.6)	1,240 (5.6)	1,580 (7.1)	1,440 (6.5)	1,620 (7.3)	1,740 (7.8)	1,620 (7.3)
	1 1/2 (38.1)	1,635 (7.4)	1,580 (7.1)	2,080 (9.4)	1,620 (7.3)	2,100 (9.5)	1,620 (7.3)
	2 (50.8)	1,900 (8.6)	1,580 (7.1)	2,080 (9.4)	1,620 (7.3)	2,100 (9.5)	1,620 (7.3)
3/8 (9.5)	1 5/8 (41.3)	1,920 (8.6)	3,560 (16.0)	3,040 (13.7)	3,760 (16.9)	3,040 (13.7)	3,760 (16.9)
	2 (50.8)	2,800 (12.6)	3,560 (16.0)	3,850 (17.3)	3,760 (16.9)	4,075 (18.3)	3,760 (16.9)
	3 (76.2)	4,100 (18.5)	3,560 (16.0)	4,200 (18.7)	3,760 (16.9)	4,200 (18.7)	3,760 (16.9)
1/2 (12.7)	2 1/4 (57.2)	3,440 (15.5)	6,540 (29.4)	5,560 (25.0)	6,800 (30.6)	6,540 (29.4)	6,800 (30.6)
	3 (76.2)	5,100 (23.0)	6,540 (29.4)	6,540 (29.4)	6,800 (30.6)	6,540 (29.4)	6,800 (30.6)
	4 (101.6)	5,700 (25.7)	6,540 (29.4)	6,540 (29.4)	6,800 (30.6)	6,540 (29.4)	6,800 (30.6)
5/8 (15.9)	2 3/4 (69.9)	6,240 (27.8)	9,280 (41.8)	8,300 (37.4)	11,900 (53.6)	8,860 (39.4)	11,900 (53.6)
	4 (101.6)	7,125 (31.7)	9,280 (41.8)	9,000 (40.0)	11,900 (53.6)	9,000 (40.0)	11,900 (53.6)
3/4 (19.1)	3 3/8 (85.7)	7,420 (33.0)	12,380 (55.7)	9,500 (42.3)	15,060 (67.8)	10,250 (45.6)	15,060 (67.8)
	5 (127.0)	10,640 (47.3)	12,380 (55.7)	10,640 (47.3)	15,060 (67.8)	10,640 (47.3)	15,060 (67.8)
7/8 (22.2)	3 7/8 (98.4)	7,600 (34.2)	17,960 (80.8)	12,300 (55.4)	24,160 (108.7)	12,500 (55.6)	24,160 (108.7)
	4 1/2 (114.3)	9,600 (43.2)	17,960 (80.8)	12,500 (55.6)	24,160 (108.7)	12,500 (55.6)	24,160 (108.7)
	5 3/4 (146.1)	10,640 (47.3)	17,960 (80.8)	12,500 (55.6)	24,160 (108.7)	12,500 (55.6)	24,160 (108.7)
1 (25.4)	4 1/2 (114.3)	8,740 (39.3)	26,420 (118.9)	13,820 (62.2)	31,100 (140.0)	17,125 (76.2)	31,100 (140.0)
	5 1/2 (139.7)	12,770 (57.5)	26,420 (118.9)	17,125 (76.2)	31,100 (140.0)	17,125 (76.2)	31,100 (140.0)
	6 1/2 (165.1)	16,605 (74.7)	26,420 (118.9)	17,125 (76.2)	31,100 (140.0)	17,125 (76.2)	31,100 (140.0)

1. Tabulated load values are for anchors installed in concrete. Concrete compressive strength must be at the specified minimum at the time of installation.
 2. Ultimate load capacities must be reduced by a minimum safety factor of 4.0 or greater to determine allowable working load. Consideration of safety factors of 10 or higher may be necessary depending upon the application such as life safety or overhead.

PERFORMANCE DATA

Allowable Load Capacities for Stainless Steel Power-Stud in Normal-Weight Concrete^{1,2}

Anchor Diameter <i>d</i> in. (mm)	Minimum Embedment Depth <i>h_v</i> in. (mm)	Minimum Concrete Compressive Strength (<i>f'_c</i>)					
		2,000 psi (13.8 MPa)		4,000 psi (27.6 MPa)		6,000 psi (41.4 MPa)	
		Tension lbs. (kN)	Shear lbs. (kN)	Tension lbs. (kN)	Shear lbs. (kN)	Tension lbs. (kN)	Shear lbs. (kN)
1/4 (6.4)	1 1/8 (28.6)	310 (1.4)	395 (1.8)	360 (1.6)	405 (1.8)	435 (2.0)	405 (1.8)
	1 1/2 (38.1)	410 (1.8)	395 (1.8)	520 (2.3)	405 (1.8)	525 (2.4)	405 (1.8)
	2 (50.8)	475 (2.1)	395 (1.8)	520 (2.3)	405 (1.8)	525 (2.4)	405 (1.8)
3/8 (9.5)	1 5/8 (41.3)	480 (2.2)	890 (4.0)	760 (3.4)	940 (4.2)	760 (3.4)	940 (4.2)
	2 (50.8)	700 (3.2)	890 (4.0)	965 (4.3)	940 (4.2)	1,020 (4.6)	940 (4.2)
	3 (76.2)	1,025 (4.6)	890 (4.0)	1,050 (4.7)	940 (4.2)	1,050 (4.7)	940 (4.2)
1/2 (12.7)	2 1/4 (57.2)	860 (3.9)	1,635 (7.4)	1,390 (6.3)	1,700 (7.7)	1,635 (7.4)	1,700 (7.7)
	3 (76.2)	1,275 (5.7)	1,635 (7.4)	1,635 (7.3)	1,700 (7.7)	1,635 (7.3)	1,700 (7.7)
	4 (101.6)	1,425 (6.4)	1,635 (7.4)	1,635 (7.3)	1,700 (7.7)	1,635 (7.3)	1,700 (7.7)
5/8 (15.9)	2 3/4 (69.9)	1,560 (6.9)	2,320 (10.4)	2,075 (9.3)	2,975 (13.4)	2,215 (9.9)	2,975 (13.4)
	4 (101.6)	1,780 (7.9)	2,320 (10.4)	2,250 (10.0)	2,975 (13.4)	2,250 (10.0)	2,975 (13.4)
3/4 (19.1)	3 3/8 (85.7)	1,855 (8.3)	3,095 (13.9)	2,375 (10.6)	3,765 (16.9)	2,560 (11.4)	3,765 (16.9)
	5 (127.0)	2,660 (11.8)	3,095 (13.9)	2,660 (11.8)	3,765 (16.9)	2,660 (11.8)	3,765 (16.9)
7/8 (22.2)	3 7/8 (98.4)	1,900 (8.6)	4,490 (20.2)	3,075 (13.8)	6,040 (27.2)	3,125 (13.9)	6,040 (27.2)
	4 1/2 (114.3)	2,400 (10.8)	4,490 (20.2)	3,125 (13.9)	6,040 (27.2)	3,125 (13.9)	6,040 (27.2)
	5 3/4 (146.1)	2,660 (11.8)	4,490 (20.2)	3,125 (13.9)	6,040 (27.2)	3,125 (13.9)	6,040 (27.2)
1 (25.4)	4 1/2 (114.3)	2,185 (9.8)	6,605 (29.7)	3,455 (15.5)	7,775 (35.0)	4,280 (19.0)	7,775 (35.0)
	5 1/2 (139.7)	3,195 (14.4)	6,605 (29.7)	4,280 (19.0)	7,775 (35.0)	4,280 (19.0)	7,775 (35.0)
	6 1/2 (165.1)	4,150 (18.7)	6,605 (29.7)	4,280 (19.0)	7,775 (35.0)	4,280 (19.0)	7,775 (35.0)

1. Allowable load capacities listed are calculated using and applied safety factor of 4.0. Consideration of safety factors of 10 or higher may be necessary depending upon the application such as life safety or overhead.
2. Allowable load capacities are multiplied by reduction factors found in the Design Criteria section when anchor spacing or edge distances are less than critical distances.
3. Linear interpolation may be used to determine allowable loads for intermediate embedments and compressive strengths.

PERFORMANCE DATA

Ultimate and Allowable Load Capacities for Mechanically Galvanized Carbon and Stainless Steel Power-Stud in Structural Lightweight Concrete^{1,2}

Anchor Diameter <i>d</i> in. (mm)	Install Torque <i>T_{inst}</i> ft.-lbs.	Min. Embed. Depth <i>h_v</i> in. (mm)	Minimum Concrete Compressive Strength (<i>f'_c</i>)						Shear, lbs (kN)	
			Tension, lbs (kN)							
			3,000 psi (20.7 MPa)		4,000 psi (27.6 MPa)		5,000 psi (34.5 MPa)		<i>f'_c</i> ≥ 3,000 psi (20.7 MPa)	
			Ultimate Load	Allowable Load	Ultimate Load	Allowable Load	Ultimate Load	Allowable Load	Ultimate Load	Allowable Load
1/4 (6.4)	4	1 1/8 (28.6)	720 (3.2)	180 (0.8)	960 (4.3)	240 (1.1)	1,200 (5.4)	300 (1.4)	720 (3.2)	180 (0.8)
3/8 (9.5)	20	1 5/8 (41.3)	1,600 (7.2)	400 (1.8)	1,940 (8.7)	485 (2.2)	2,300 (10.4)	575 (2.6)	1,840 (8.3)	460 (2.1)
		3 (76.2)	–	–	2,860 (12.9)	715 (3.2)	–	–	1,840 (8.3)	460 (2.1)
1/2 (12.7)	30	2 1/4 (57.2)	2,820 (12.7)	705 (3.2)	3,180 (14.3)	795 (3.6)	3,560 (16.0)	890 (4.0)	5,040 (22.7)	1,260 (5.7)
		4 (101.6)	–	–	4,200 (18.9)	1,050 (4.7)	–	–	5,040 (22.7)	1,260 (5.7)
5/8 (15.9)	65	2 3/4 (69.9)	4,380 (19.7)	1,095 (4.9)	4,980 (22.4)	1,245 (5.6)	5,580 (25.1)	1,395 (6.3)	6,940 (31.2)	1,735 (7.8)
		5 (127.0)	–	–	6,920 (31.1)	1,730 (7.8)	–	–	6,940 (31.2)	1,735 (7.8)
3/4 (19.1)	90	3 3/8 (85.7)	5,060 (22.8)	1,265 (5.7)	5,600 (25.2)	1,400 (6.3)	6,140 (27.6)	1,535 (6.9)	9,880 (44.5)	2,470 (11.1)
		5 (127.0)	–	–	9,300 (41.9)	2,325 (10.5)	–	–	9,880 (44.5)	2,470 (11.1)

1. Tabulated load values are for anchors installed in sand-lightweight concrete. Concrete compressive strength must be at the specified minimum at the time of installation.
2. Allowable load capacities listed are calculated using an applied safety factor of 4.0. Consideration of safety factors of 10 or higher may be necessary depending upon the application such as life safety or overhead.
3. Allowable load capacities are multiplied by reduction factors found in the Design Criteria section when anchor spacing or edge distances are less than critical distances.

PERFORMANCE DATA

Ultimate and Allowable Load Capacities for Carbon Steel Power-Stud Installed Through Metal Deck into Structural Lightweight Concrete^{1,2,3,4}

Anchor Diameter <i>d</i> in. (mm)	Install Torque <i>T_{inst}</i> ft.-lbs.	Min. Embed. Depth <i>h_v</i> in. (mm)	Lightweight Concrete over minimum 20 Gage Metal Deck, <i>f'_c</i> ≥ 3,000 (20.7 MPa)							
			Minimum 1-1/2" Wide Deck				Minimum 4-1/2" Wide Deck			
			Ultimate Load		Allowable Load		Ultimate Load		Allowable Load	
			Tension lbs. (kN)	Shear lbs. (kN)	Tension lbs. (kN)	Shear lbs. (kN)	Tension lbs. (kN)	Shear lbs. (kN)	Tension lbs. (kN)	Shear lbs. (kN)
1/4 (6.4)	4	1 1/8 (28.6)	880 (4.0)	1,840 (8.3)	220 (1.0)	460 (2.1)	880 (4.0)	1,840 (8.3)	220 (1.0)	460 (2.1)
3/8 (9.5)	20	1 5/8 (41.3)	880 (4.0)	2,800 (12.6)	220 (1.0)	700 (3.2)	1,520 (6.8)	2,800 (12.6)	380 (1.7)	700 (3.2)
		3 (76.2)	880 (4.0)	2,800 (12.6)	220 (1.0)	700 (3.2)	4,480 (20.2)	3,840 (17.3)	1,120 (5.0)	960 (4.3)
1/2 (12.7)	30	2 1/4 (57.2)	1,400 (6.3)	2,800 (12.6)	350 (1.6)	700 (3.2)	3,200 (14.4)	4,780 (21.5)	800 (3.6)	1,195 (5.4)
		4 (101.6)	1,400 (6.3)	2,800 (12.6)	350 (1.6)	700 (3.2)	6,360 (28.6)	7,540 (33.9)	1,590 (7.2)	1,885 (8.5)
5/8 (15.9)	65	2 3/4 (69.9)	-	-	-	-	3,200 (14.4)	4,780 (21.5)	800 (3.6)	1,195 (5.4)
		5 (127.0)	-	-	-	-	9,200 (41.4)	10,940 (49.2)	2,300 (10.4)	2,735 (12.3)
3/4 (19.1)	90	3 3/8 (85.7)	-	-	-	-	2,740 (12.3)	7,000 (31.5)	685 (3.1)	1,750 (7.9)
		5 (127.0)	-	-	-	-	10,840 (48.8)	12,570 (56.6)	2,710 (12.2)	3,140 (14.1)

1. Tabulated load values are for anchors installed in sand-lightweight concrete. Concrete compressive strength must be at the specified minimum at the time of installation.
2. Allowable loads capacities are calculated using an applied safety factor of 4.0. Consideration of safety factors of 10 or higher may be necessary depending on the application, such as life safety or overhead.
3. Tabulated load values are for anchors installed in the center of the flute. Spacing distances shall be in accordance with the spacing table for lightweight concrete listed in the Design Criteria section. Linear interpolation may be used for flute edge distances between those listed. Flute edge distance equals one-half the minimum deck width.
4. Anchors are permitted to be installed in the lower or upper flute of the metal deck provided the proper installation procedures are maintained.

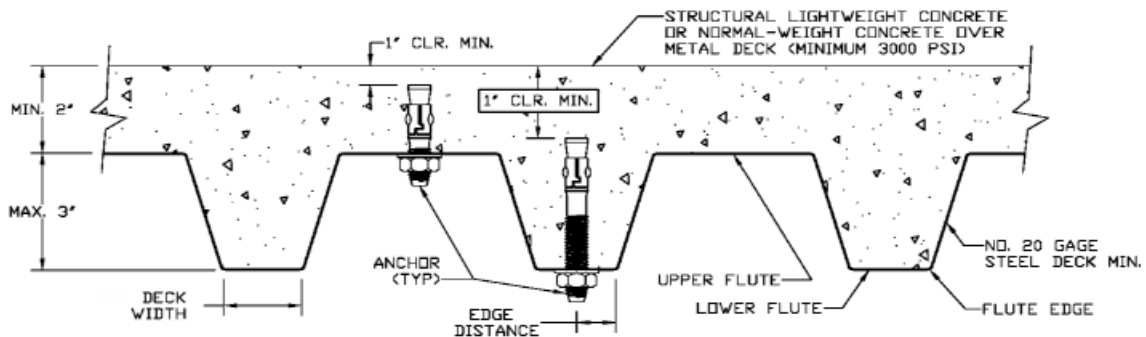

PERFORMANCE DATA

Ultimate and Allowable Load Capacities for Mechanically Galvanized and Stainless Steel Power-Stud in Grout-Filled Concrete Masonry^{1,2,3}

MECHANICAL ANCHORS

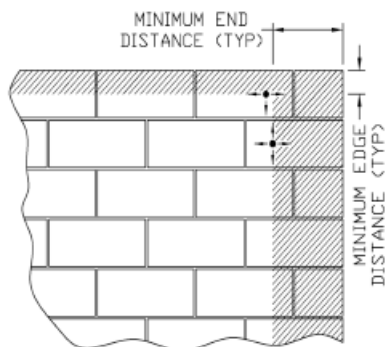

Anchor Dia. <i>d</i> in. (mm)	Install Torque <i>T_{inst}</i> ft.-lbs.	Min. Embed. Depth <i>h_v</i> in. (mm)	Min. Edge Distance in. (mm)	Min. End Distance in. (mm)	Grout-Filled Concrete Masonry <i>f'_m</i> ≥ 1,500 psi (10.4 MPa)			
					Ultimate Load		Allowable Load	
					Tension lbs. (kN)	Shear lbs. (kN)	Tension lbs. (kN)	Shear lbs. (kN)
1/4 (6.4)	4	1 1/8 (28.6)	3 3/4 (95.3)	3 3/4 (95.3)	1,230 (5.5)	1,230 (5.5)	245 (1.1)	245 (1.1)
		2 (50.8)	5 1/4 (133.4)	3 3/4 (95.3)	1,670 (7.5)	1,230 (5.5)	335 (1.5)	245 (1.1)
3/8 (9.5)	20	1 5/8 (41.3)	5 5/8 (142.9)	5 5/8 (142.9)	1,990 (9.0)	3,240 (14.6)	400 (1.8)	650 (2.9)
		3 (76.2)	7 7/8 (200.0)	5 5/8 (142.9)	2,200 (9.9)	3,240 (14.6)	440 (2.0)	650 (2.9)
1/2 (12.7)	30	2 1/4 (57.2)	7 1/2 (190.5)	7 1/2 (190.5)	2,260 (10.2)	6,230 (28.0)	450 (2.0)	1,245 (5.6)
		4 (101.6)	10 1/2 (266.7)	7 1/2 (190.5)	2,620 (11.8)	6,230 (28.0)	525 (2.4)	1,245 (5.6)
5/8 (15.9)	65	2 3/4 (69.9)	9 3/8 (238.1)	9 3/8 (238.1)	3,170 (14.3)	7,830 (35.2)	635 (2.9)	1,565 (7.0)
		5 (127.0)	13 1/8 (333.4)	9 3/8 (238.1)	3,780 (17.0)	7,830 (35.2)	755 (3.4)	1,565 (7.0)
3/4 (19.1)	90	3 3/8 (85.7)	11 1/4 (285.8)	11 1/4 (285.8)	4,085 (18.4)	9,760 (43.9)	815 (3.7)	1,950 (8.8)
		5 (127.0)	15 3/4 (400.1)	11 1/4 (285.8)	4,420 (19.9)	9,760 (43.9)	885 (4.0)	1,950 (8.8)

1. Tabulated load values are for anchors installed in minimum 6-inch wide, Grade N, Type II, medium and normal-weight concrete masonry units conforming to ASTM C 90 that have reached the minimum designated ultimate compressive strength at the time of installation (*f'_m* ≥ 1,500 psi).
2. Allowable load capacities listed are calculated using an applied safety factor of 5.0. Consideration of safety factors of 10 or higher may be necessary depending on the application, such as life safety or overhead.
3. The tabulated values are for anchors installed at a minimum of 12 anchor diameters on center for 100 percent capacity. Spacing distances may be reduced to 6 anchor diameters on center provided the capacities are reduced by 50 percent. Linear interpolation may be used for intermediate spacing.

DESIGN CRITERIA (ALLOWABLE STRESS DESIGN)

Combined Loading

For anchors loaded in both shear and tension, the combination of loads should be proportioned as follows:

$$\left(\frac{N_u}{N_n}\right)^{\frac{5}{3}} + \left(\frac{V_u}{V_n}\right)^{\frac{5}{3}} \leq 1 \quad \text{OR} \quad \left(\frac{N_u}{N_n}\right) + \left(\frac{V_u}{V_n}\right) \leq 1$$

Where: *N_u* = Applied Service Tension Load
N_n = Allowable Tension Load
V_u = Applied Service Shear Load
V_n = Allowable Shear Load

Load Adjustment Factors for Spacing and Edge Distances¹

Anchor Installed in Normal-Weight Concrete					
Anchor Dimension	Load Type	Critical Distance (Full Anchor Capacity)	Critical Load Factor	Minimum Distance (Reduced Capacity)	Minimum Load Factor
Spacing (<i>s</i>)	Tension and Shear	<i>s_{cr}</i> = 2.0 <i>h_v</i>	<i>F_{N_S}</i> = <i>F_{V_S}</i> = 1.0	<i>s_{min}</i> = <i>h_v</i>	<i>F_{N_S}</i> = <i>F_{V_S}</i> = 0.50
Edge Distance (<i>c</i>)	Tension	<i>c_{cr}</i> = 12 <i>d</i>	<i>F_{N_C}</i> = 1.0	<i>c_{min}</i> = 5 <i>d</i>	<i>F_{N_C}</i> = 0.75
	Shear	<i>c_{cr}</i> = 12 <i>d</i>	<i>F_{V_C}</i> = 1.0	<i>c_{min}</i> = 5 <i>d</i>	<i>F_{V_C}</i> = 0.75

Anchor Installed in Lightweight Concrete					
Anchor Dimension	Load Type	Critical Distance (Full Anchor Capacity)	Critical Load Factor	Minimum Distance (Reduced Capacity)	Minimum Load Factor
Spacing (<i>s</i>)	Tension and Shear	<i>s_{cr}</i> = 2.0 <i>h_v</i>	<i>F_{N_S}</i> = <i>F_{V_S}</i> = 1.0	<i>s_{min}</i> = <i>h_v</i>	<i>F_{N_S}</i> = <i>F_{V_S}</i> = 0.50
Edge Distance (<i>c</i>)	Tension	<i>c_{cr}</i> = 12 <i>d</i>	<i>F_{N_C}</i> = 1.0	<i>c_{min}</i> = 5 <i>d</i>	<i>F_{N_C}</i> = 0.95
	Shear	<i>c_{cr}</i> = 12 <i>d</i>	<i>F_{V_C}</i> = 1.0	<i>c_{min}</i> = 5 <i>d</i>	<i>F_{V_C}</i> = 0.30

1. Allowable load values found in the performance data tables are multiplied by reduction factors when anchor spacing or edge distances are less than critical distances. Linear interpolation is allowed for intermediate anchor spacing and edge distances between critical and minimum distances. When an anchor is affected by both reduced spacing and edge distance, the spacing and edge reduction factors must be combined (multiplied). Multiple reduction factors for anchor spacing and edge distance may be required depending on the anchor group configuration.

DESIGN CRITERIA (ALLOWABLE STRESS DESIGN)

Spacing Load Adjustment Factors for Normal-Weight and Lightweight Concrete (Continued Below)

Spacing, Tension (F_{N_S}) & Shear (F_{V_S})																		
Dia. (in.)	1/4				3/8				1/2				5/8					
h_v (in.)	1 1/8	1 1/2	2	2 3/4	1 5/8	2	3	4 1/4	2 1/4	3	4	5	6	2 3/4	3 1/2	4	5	7
s_{cr} (in.)	2 1/4	3	4	5 1/2	3 1/4	4	6	8 1/2	4 1/2	6	8	10	12	5 1/2	7	8	10	14
s_{min} (in.)	1 1/8	1 1/2	2	2 3/4	1 5/8	2	3	4 1/4	2 1/4	3	4	5	6	2 3/4	3 1/2	4	5	7
Spacing, s (inches)	1 1/8	0.50																
	1 1/2	0.67	0.50															
	1 5/8	0.72	0.54			0.50												
	2	0.89	0.67	0.50		0.62	0.50											
	2 1/4	1.00	0.75	0.56		0.69	0.56			0.50								
	2 3/4		0.92	0.69	0.50	0.85	0.69			0.61				0.50				
	3		1.00	0.75	0.55	0.92	0.75	0.50		0.67	0.50			0.55				
	3 1/4			0.81	0.59	1.00	0.81	0.54		0.72	0.54			0.59				
	3 1/2			0.88	0.64		0.88	0.58		0.78	0.58			0.64	0.50			
	4			1.00	0.73		1.00	0.67		0.89	0.67	0.50		0.73	0.57	0.50		
	4 1/4				0.77			0.71	0.50	0.94	0.71	0.53		0.77	0.61	0.53		
	4 1/2				0.82			0.75	0.53	1.00	0.75	0.56		0.82	0.64	0.56		
	5				0.91			0.83	0.59		0.83	0.63	0.50	0.91	0.71	0.63	0.50	
	5 1/2				1.00			0.92	0.65		0.92	0.69	0.55	1.00	0.79	0.69	0.55	
6							1.00	0.71		1.00	0.75	0.60	0.50	0.86	0.75	0.60		
7								0.82			0.88	0.70	0.58	1.00	0.88	0.70	0.50	
8								0.94			1.00	0.80	0.67	1.00	0.80	0.57		
8 1/2								1.00				0.85	0.71		0.85	0.61		
10												1.00	0.83		1.00	0.71		
11													0.92			0.79		
12													1.00			0.86		
13																0.93		
14																1.00		

Spacing Load Adjustment Factors for Normal-Weight and Lightweight Concrete (Continued from Above)

Spacing, Tension (F_{N_S}) & Shear (F_{V_S})																	
Dia. (in.)	3/4					7/8					1						
h_v (in.)	3 3/8	4	5	6	8	3 7/8	4 1/2	5 3/4	7	8	4 1/2	5 1/2	6 1/2	8	9		
s_{cr} (in.)	6 3/4	8	10	12	16	7 3/4	9	11 1/2	14	16	9	11	13	16	18		
s_{min} (in.)	3 3/8	4	5	6	8	3 7/8	4 1/2	5 3/4	7	8	4 1/2	5 1/2	6 1/2	8	9		
Spacing, s (inches)	3 3/8	0.50															
	3 7/8	0.57				0.50											
	4	0.59	0.50			0.52											
	4 1/2	0.67	0.56			0.58	0.50				0.50						
	5	0.74	0.63	0.50		0.65	0.56				0.56						
	5 1/2	0.81	0.69	0.55		0.71	0.61				0.61	0.50					
	5 3/4	0.85	0.72	0.58		0.74	0.64	0.50			0.64	0.52					
	6	0.89	0.75	0.60	0.50	0.77	0.67	0.52			0.67	0.55					
	6 1/2	0.96	0.81	0.65	0.54	0.84	0.72	0.57			0.72	0.59	0.50				
	6 3/4	1.00	0.84	0.68	0.56	0.87	0.75	0.59			0.75	0.61	0.52				
	7		0.88	0.70	0.58	0.90	0.78	0.61	0.50		0.78	0.64	0.54				
	7 3/4		0.97	0.78	0.65	1.00	0.86	0.67	0.55		0.86	0.70	0.60				
	8		1.00	0.80	0.67	0.50	0.89	0.70	0.57	0.50	0.89	0.73	0.62	0.50			
	9			0.90	0.75	0.56	1.00	0.78	0.64	0.56	1.00	0.82	0.69	0.56	0.50		
	10			1.00	0.83	0.63		0.87	0.71	0.63		0.91	0.77	0.63	0.56		
	11				0.92	0.69		0.96	0.79	0.69		1.00	0.85	0.69	0.61		
	11 1/2				0.96	0.72		1.00	0.82	0.72			0.88	0.72	0.64		
12				1.00	0.75			0.86	0.75			0.92	0.75	0.67			
13					0.81			0.93	0.81			1.00	0.81	0.72			
14					0.88			1.00	0.88				0.88	0.78			
16					1.00				1.00				1.00	0.89			
18														1.00			
20																	

Notes: Critical spacing (s_{cr}) is equal to 2 embedment depths ($2h_v$) at which the anchor achieves 100% of load.

Minimum spacing (s_{min}) is equal to 1 embedment depth (h_v) at which the anchor achieves 50% of load.

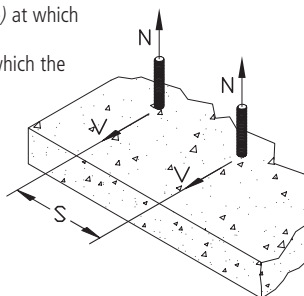

DESIGN CRITERIA (ALLOWABLE STRESS DESIGN)

Edge Distance Load Adjustment Factors for Normal-Weight Concrete

Edge Distance, Tension (F_{Nc})								
Diameter (in.)	1/4	3/8	1/2	5/8	3/4	7/8	1	
c_{cr} (in.)	3	4 1/2	6	7 1/2	9	10 1/2	12	
c_{min} (in.)	1 1/4	1 7/8	2 1/2	3 1/8	3 3/4	4 3/8	5	
Edge Distance, c (inches)	1 1/4	0.75						
	1 5/8	0.80						
	1 7/8	0.84	0.75					
	2	0.86	0.76					
	2 1/2	0.93	0.81	0.75				
	3	1.00	0.86	0.79				
	3 1/8		0.87	0.79	0.75			
	3 3/4		0.93	0.84	0.79	0.75		
	4		0.95	0.86	0.80	0.76		
	4 3/8		0.99	0.88	0.82	0.78	0.75	
	4 1/2		1.00	0.89	0.83	0.79	0.76	
	5			0.93	0.86	0.81	0.78	0.75
	6			1.00	0.91	0.86	0.82	0.79
	6 1/4				0.93	0.87	0.83	0.79
	7				0.97	0.90	0.86	0.82
7 1/2				1.00	0.93	0.88	0.84	
8					0.95	0.90	0.86	
9					1.00	0.94	0.89	
10 1/2						1.00	0.95	
12							1.00	
15								

Notes: For anchors loaded in tension, the critical edge distance (c_{cr}) is equal to 12 anchor diameters ($12d$) at which the anchor achieves 100% of load. Minimum edge distance (c_{min}) is equal to 5 anchor diameters ($5d$) at which the anchor achieves 75% of load.

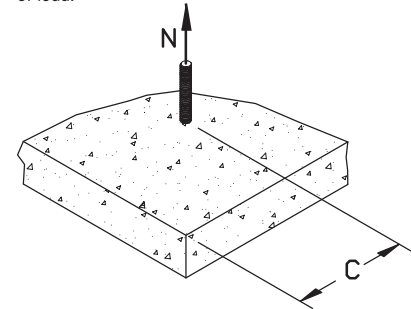

Edge Distance, Shear (F_{Vc})								
Diameter (in.)	1/4	3/8	1/2	5/8	3/4	7/8	1	
c_{cr} (in.)	3	4 1/2	6	7 1/2	9	10 1/2	12	
c_{min} (in.)	1 1/4	1 7/8	2 1/2	3 1/8	3 3/4	4 3/8	5	
Edge Distance, c (inches)	1 1/4	0.35						
	1 5/8	0.49						
	1 7/8	0.58	0.35					
	2	0.63	0.38					
	2 1/2	0.81	0.50	0.35				
	3	1.00	0.63	0.44				
	3 1/8		0.66	0.47	0.35			
	3 3/4		0.81	0.58	0.44	0.35		
	4		0.88	0.63	0.48	0.38		
	4 3/8		0.97	0.70	0.54	0.43	0.35	
	4 1/2		1.00	0.72	0.55	0.44	0.36	
	5			0.81	0.63	0.50	0.42	0.35
	6			1.00	0.78	0.63	0.52	0.44
	6 1/4				0.81	0.66	0.55	0.47
	7				0.93	0.75	0.63	0.54
7 1/2				1.00	0.81	0.68	0.58	
8					0.88	0.73	0.63	
9					1.00	0.84	0.72	
10 1/2						1.00	0.86	
12							1.00	
15								

Notes: For anchors loaded in shear, the critical edge distance (c_{cr}) is equal to 12 anchor diameters ($12d$) at which the anchor achieves 100% of load.

Minimum edge distance (c_{min}) is equal to 5 anchor diameters ($5d$) at which the anchor achieves 35% of load.

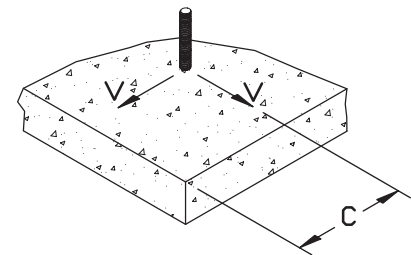

DESIGN CRITERIA (ALLOWABLE STRESS DESIGN)

Edge Distance Load Adjustment Factors for Lightweight Concrete

Edge Distance, Tension (F_{Nc})								
Diameter (in.)	1/4	3/8	1/2	5/8	3/4	7/8	1	
C_{cr} (in.)	3	4 1/2	6	7 1/2	9	10 1/2	12	
C_{min} (in.)	1 1/4	1 7/8	2 1/2	3 1/8	3 3/4	4 3/8	5	
Edge Distance, c (inches)	1 1/4	0.95						
	1 5/8	0.96						
	1 7/8	0.97	0.95					
	2	0.97	0.95					
	2 1/2	0.99	0.96	0.95				
	3	1.00	0.97	0.96				
	3 1/8		0.97	0.96	0.95			
	3 3/4		0.99	0.97	0.96	0.95		
	4		0.99	0.97	0.96	0.95		
	4 3/8		1.00	0.98	0.96	0.96	0.95	
	4 1/2		1.00	0.98	0.97	0.96	0.95	
	5			0.99	0.97	0.96	0.96	0.95
	6			1.00	0.98	0.97	0.96	0.96
	6 1/4				0.99	0.97	0.97	0.96
	7				0.99	0.98	0.97	0.96
7 1/2				1.00	0.99	0.98	0.97	
8					0.99	0.98	0.97	
9					1.00	0.99	0.98	
10 1/2						1.00	0.99	
12							1.00	
15								

Notes: For anchors loaded in tension, the critical edge distance (c_{cr}) is equal to 12 anchor diameters ($12d$) at which the anchor achieves 100% of load. Minimum edge distance (c_{min}) is equal to 5 anchor diameters ($5d$) at which the anchor achieves 95% of load.

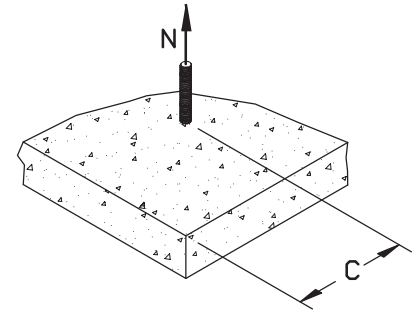

Edge Distance, Shear (F_{Vc})								
Diameter (in.)	1/4	3/8	1/2	5/8	3/4	7/8	1	
C_{cr} (in.)	3	4 1/2	6	7 1/2	9	10 1/2	12	
C_{min} (in.)	1 1/4	1 7/8	2 1/2	3 1/8	3 3/4	4 3/8	5	
Edge Distance, c (inches)	1 1/4	0.30						
	1 5/8	0.45						
	1 7/8	0.55	0.30					
	2	0.60	0.33					
	2 1/2	0.80	0.47	0.30				
	3	1.00	0.60	0.40				
	3 1/8		0.63	0.43	0.30			
	3 3/4		0.80	0.55	0.40	0.30		
	4		0.87	0.60	0.44	0.33		
	4 3/8		0.97	0.68	0.50	0.38	0.30	
	4 1/2		1.00	0.70	0.52	0.40	0.31	
	5			0.80	0.60	0.47	0.37	0.30
	6			1.00	0.76	0.60	0.49	0.40
	6 1/4				0.80	0.63	0.51	0.43
	7				0.92	0.73	0.60	0.50
7 1/2				1.00	0.80	0.66	0.55	
8					0.87	0.71	0.60	
9					1.00	0.83	0.70	
10 1/2						1.00	0.85	
12							1.00	
15								

Notes: For anchors loaded in shear, the critical edge distance (c_{cr}) is equal to 12 anchor diameters ($12d$) at which the anchor achieves 100% of load.

Minimum edge distance (c_{min}) is equal to 5 anchor diameters ($5d$) at which the anchor achieves 30% of load.

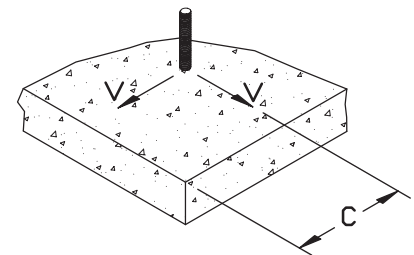

ORDERING INFORMATION

Mechanically Galvanized Carbon Steel Power-Stud

Cat. No.	Anchor Size	Min. Embed.	Thread Length	Std. Box	Std. Carton	Wt./100	FM or UL
7720	1/2" x 2 3/4"	2 1/4"	1 3/8"	50	200	18	UL
7723	1/2" x 4 1/2"	2 1/4"	3 1/8"	50	200	30	FM/UL
7724	1/2" x 5 1/2"	2 1/4"	4 1/8"	50	150	34	FM/UL
7726	1/2" x 7"	2 1/4"	5 5/8"	25	100	34	UL
7730	5/8" x 3 1/2"	2 3/4"	2"	25	100	40	UL
7734	5/8" x 6"	2 3/4"	4 1/2"	25	75	64	FM/UL
7741	3/4" x 4 3/4"	3 3/8"	2 7/8"	20	60	76	UL
7742	3/4" x 5 1/2"	3 3/8"	3 5/8"	20	60	85	FM/UL
7748	3/4" x 8 1/2"	3 3/8"	6 5/8"	10	40	120	FM/UL
7750	7/8" x 6"	3 7/8"	2 3/4"	10	40	120	FM/UL
7752	7/8" x 8"	3 7/8"	4 3/4"	10	40	160	FM/UL
7763	1" x 9"	4 1/2"	5 3/8"	10	30	240	FM



The published length is the overall length of the anchor. Allow for fixture thickness plus one anchor diameter for the nut and washer thickness when selecting a length.

Type 304 Stainless Steel Power-Stud

Cat. No.	Anchor Size	Min. Embed.	Thread Length	Std. Box	Std. Carton	Wt./100	FM or UL
7300	1/4" x 1 3/4"	1 1/8"	3/4"	100	500	3	-
7302	1/4" x 2 1/4"	1 1/8"	1 1/4"	100	500	3 1/2	-
7304	1/4" x 3 1/4"	1 1/8"	2 1/4"	100	500	4 3/4	-
7310	3/8" x 2 1/4"	1 5/8"	1 1/4"	50	250	8 3/4	FM/UL
7312	3/8" x 2 3/4"	1 5/8"	1 5/8"	50	250	9 1/2	FM/UL
7313	3/8" x 3"	1 5/8"	1 7/8"	50	250	10 3/4	UL
7314	3/8" x 3 1/2"	1 5/8"	2 3/8"	50	250	12	FM/UL
7315	3/8" x 3 3/4"	1 5/8"	2 5/8"	50	250	12 3/4	UL
7316	3/8" x 5"	1 5/8"	3 1/8"	50	250	15 1/2	UL
7320	1/2" x 2 3/4"	2 1/4"	1 3/8"	50	200	18	FM/UL
7322	1/2" x 3 3/4"	2 1/4"	2 3/8"	50	200	23	FM/UL
7323	1/2" x 4 1/2"	2 1/4"	3 1/8"	50	200	30	UL
7324	1/2" x 5 1/2"	2 1/4"	4 1/8"	50	150	34	FM/UL
7326	1/2" x 7"	2 1/4"	5 5/8"	25	100	44	FM/UL
7330	5/8" x 3 1/2"	2 3/4"	2"	25	100	40	FM/UL
7332	5/8" x 4 1/2"	2 3/4"	3"	25	100	54	FM/UL
7333	5/8" x 5"	2 3/4"	3 1/2"	25	100	57	UL
7334	5/8" x 6"	2 3/4"	4 1/2"	25	75	64	FM/UL
7336	5/8" x 7"	2 3/4"	5 1/2"	25	75	72	UL
7338	5/8" x 8 1/2"	2 3/4"	7"	25	75	84	UL
7340	3/4" x 4 1/4"	3 3/8"	2 3/8"	20	60	70	UL
7341	3/4" x 4 3/4"	3 3/8"	2 7/8"	20	60	76	UL
7342	3/4" x 5 1/2"	3 3/8"	3 5/8"	20	60	85	FM/UL
7344	3/4" x 6 1/4"	3 3/8"	4 3/8"	20	60	95	UL
7346	3/4" x 7"	3 3/8"	5 1/8"	20	60	105	UL
7348	3/4" x 8 1/2"	3 3/8"	6 5/8"	10	40	120	UL
7349	3/4" x 10"	3 3/8"	8 1/8"	10	30	135	UL
7352	7/8" x 8"	3 7/8"	4 3/4"	10	40	160	UL
7361	1" x 6"	4 1/2"	2 3/8"	10	30	170	-
7363	1" x 9"	4 1/2"	5 3/8"	10	30	240	-
7365	1" x 12"	4 1/2"	8 3/8"	5	15	300	-



The published length is the overall length of the anchor. Allow for fixture thickness plus one anchor diameter for the nut and washer thickness when selecting a length.

FM- Factory Mutual Approved
UL- Underwriters Laboratories Listed

MECHANICAL ANCHORS

ORDERING INFORMATION

Type 316 Stainless Steel Power-Stud

Cat. No.	Anchor Size	Min. Embed.	Thread Length	Std. Box	Std. Carton	Wt./100	FM or UL
7600	1/4" x 1 3/4"	1 1/8"	3/4"	100	500	3 1/4	-
7602	1/4" x 2 1/4"	1 1/8"	1 1/4"	100	500	3 3/4	-
7604	1/4" x 3 1/4"	1 1/8"	2 1/4"	100	500	5 1/4	-
7610	3/8" x 2 1/4"	1 5/8"	1 1/4"	50	250	8 3/4	-
7612	3/8" x 2 3/4"	1 5/8"	1 5/8"	50	250	10 1/2	FM/UL
7613	3/8" x 3"	1 5/8"	1 7/8"	50	250	11	FM/UL
7614	3/8" x 3 1/2"	1 5/8"	2 3/8"	50	250	12	UL
7615	3/8" x 3 3/4"	1 5/8"	2 5/8"	50	250	13	FM/UL
7616	3/8" x 5"	1 5/8"	3 1/8"	50	250	17 1/4	UL
7620	1/2" x 2 3/4"	2 1/4"	1 3/8"	50	200	18	FM/UL
7622	1/2" x 3 3/4"	2 1/4"	2 3/8"	50	200	24	FM/UL
7623	1/2" x 4 1/2"	2 1/4"	3 1/8"	50	200	30	FM/UL
7624	1/2" x 5 1/2"	2 1/4"	4 1/8"	50	150	34	UL
7626	1/2" x 7"	2 1/4"	5 5/8"	25	100	44	FM/UL
7630	5/8" x 3 1/2"	2 3/4"	2"	25	100	40	FM/UL
7632	5/8" x 4 1/2"	2 3/4"	3"	25	100	54	FM/UL
7633	5/8" x 5"	2 3/4"	3 1/2"	25	100	57	UL
7634	5/8" x 6"	2 3/4"	4 1/2"	25	75	64	FM/UL
7636	5/8" x 7"	2 3/4"	5 1/2"	25	75	72	FM/UL
7638	5/8" x 8 1/2"	2 3/4"	7"	25	75	84	UL
7640	3/4" x 4 1/4"	3 3/8"	2 3/8"	20	60	70	UL
7641	3/4" x 4 3/4"	3 3/8"	2 7/8"	20	60	76	UL
7642	3/4" x 5 1/2"	3 3/8"	3 5/8"	20	60	85	FM/UL
7644	3/4" x 6 1/4"	3 3/8"	4 3/8"	20	60	95	UL
7646	3/4" x 7"	3 3/8"	5 1/8"	20	60	105	UL
7648	3/4" x 8 1/2"	3 3/8"	6 5/8"	10	40	120	UL



The published length is the overall length of the anchor. Allow for fixture thickness plus one anchor diameter for the nut and washer thickness when selecting a length.

FM- Factory Mutual Approved
UL- Underwriters Laboratories Listed